

Team Versatility



2020-2021

Equipment Needs
➤ One, cone (8-18")

In Hand #1

1. Walk a few steps to start
2. Trot past cone (minimum distance)
3. Halt, and do a 270° LEFT Forehand Turn
4. Walk 8 steps
5. Halt, and do a 270° LEFT Haunch Turn
6. Trot back to start/finish on OFF SIDE

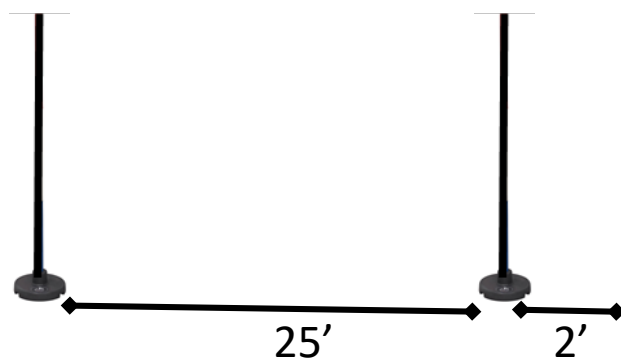
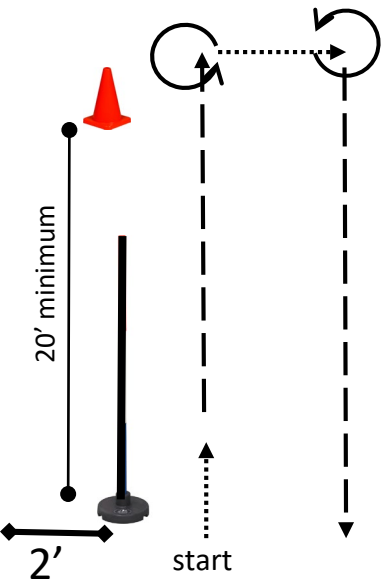

In Hand #2 *(revised 12.14.19)*

1. Trot over poles as shown
2. Halt, and do a 90° RIGHT Haunch Turn
3. Back completely through poles; **from OFF Side**
4. Pull toward "turn" (less than 90°); **from OFF Side**
5. Trot back to start/finish; **from OFF Side**

Equipment Needs
➤ Six, 8-10' Poles

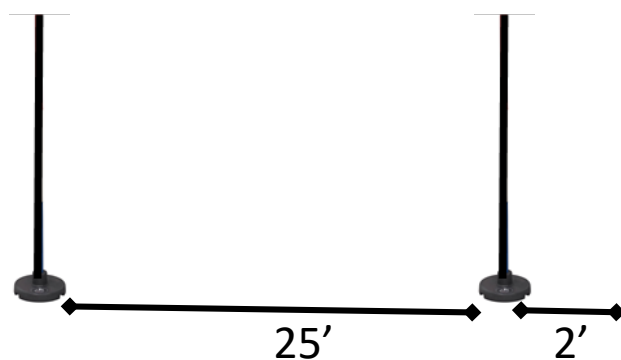
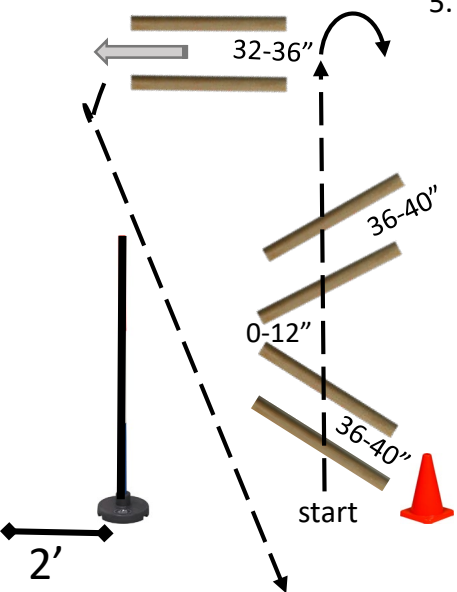

In Hand #3

1. Trot serpentine as shown from OFF SIDE
2. Circle final cone and begin a straight line to finish
3. Halt, and do a 360° LEFT Haunch Turn
4. Cross the finish line

Equipment Needs
 ➤ Five, cones of the same size (8-18")

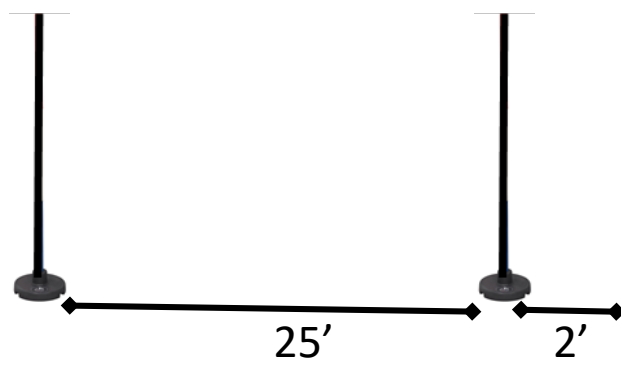
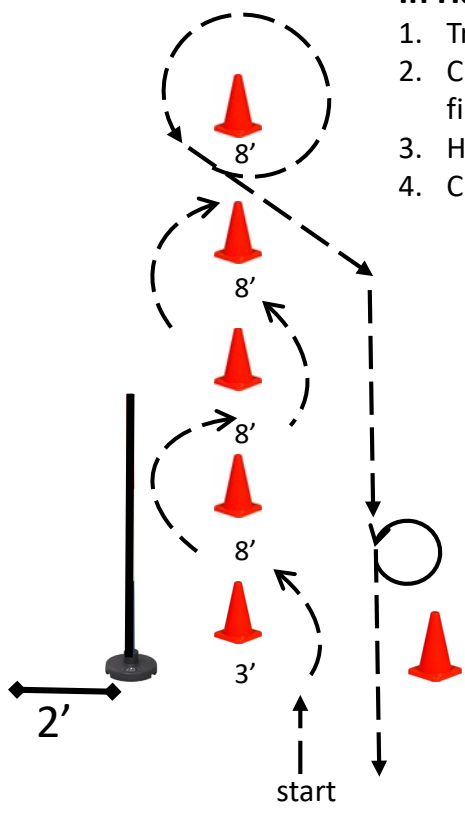

In Hand #4

1. Trot through first half of "alley"
2. Halt, Side Pass ground pole to the RIGHT
3. Trot around as shown and enter second half of "alley" from opposite end, halfway down
4. Halt, Side Pass ground pole to the LEFT
5. Trot back to start/finish

Equipment Needs
 ➤ Two, 6-8' Poles (Side Pass)
 ➤ Four, 10-12' Poles (alley)

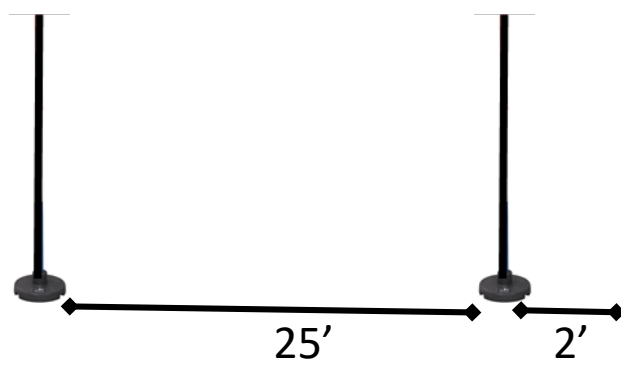
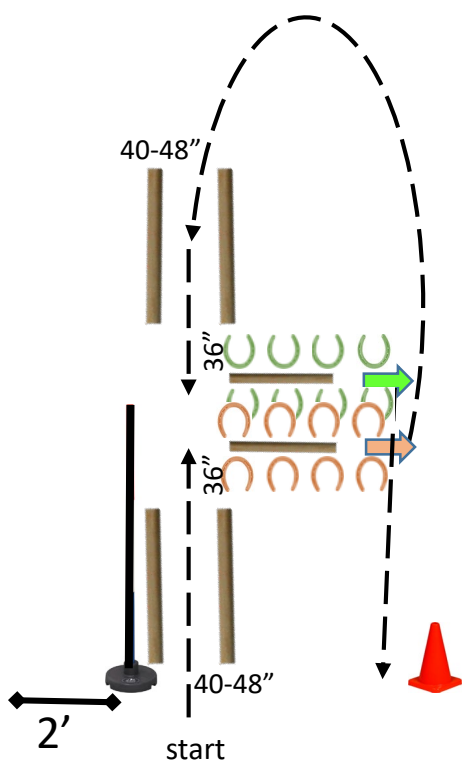

In Hand #5

1. Walk a few steps to start
2. Trot large circle to the right
3. Continue trotting until rear of horse is in line with cone
4. Halt, and back 8 steps, and close
5. Do a 180° RIGHT Haunch Turn
6. Trot **OFF SIDE** to return to start/finish line

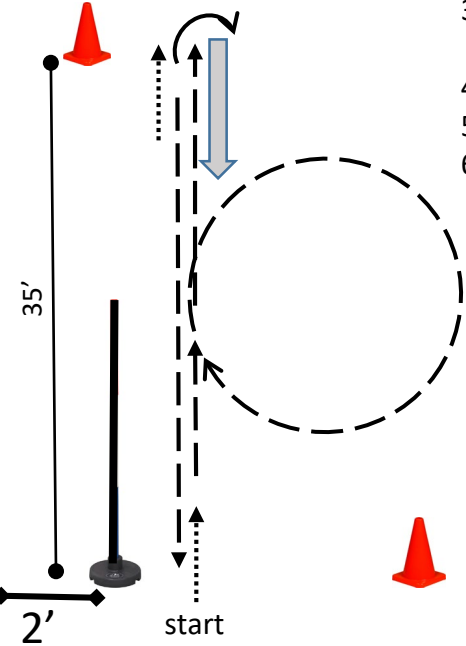

Equipment Needs
 ➤ One, cone (8-18")

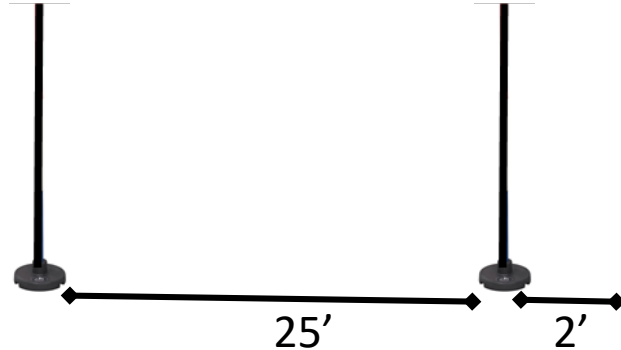

In Hand #6

1. Trot across the diagonal toward cone
2. Halt, and do a 90+° RIGHT Haunch Turn
3. Walk straight until horse's nose is in line with starting place (cone)
4. Do another 90+° RIGHT Haunch Turn until on the diagonal facing pole
5. Trot, and immediately EXTEND across the diagonal
6. Halt before pole, back 8 Steps, close and without stopping WALK across start/finish line

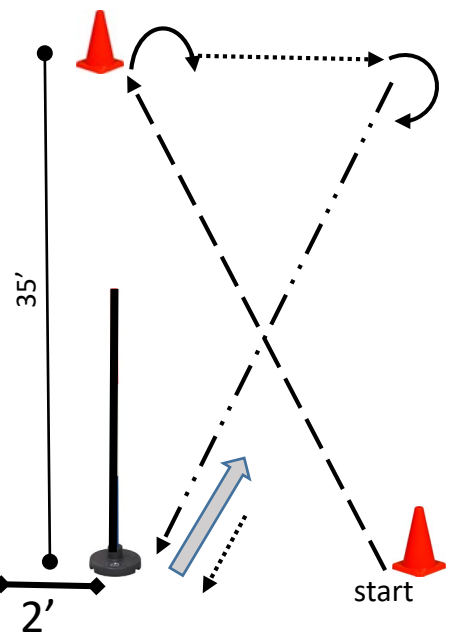

Equipment Needs
 ➤ One, cone (8-18")

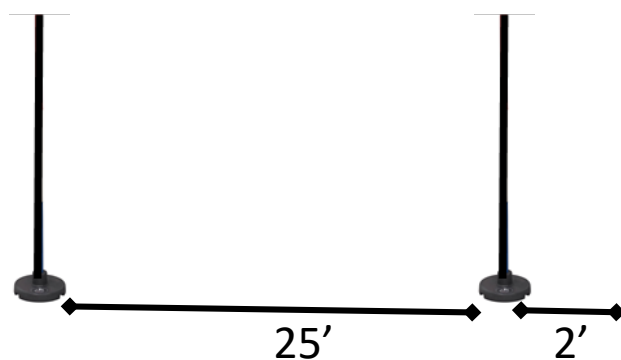

Team Versatility



2020-2021

Trail/Rancher #1

1. Trot w/energy to far pole, halt
2. Side Pass LEFT
3. When over pole, perform a 90° LEFT Haunch Turn
4. Lope/canter RIGHT Lead making large circle as shown
5. Lope/Canter over poles
6. Transition to trot
7. Trot over start/finish line

Equipment Needs

- Three, 8-10' Poles

NOTE:

Regardless of discipline, all trotting is SITTING

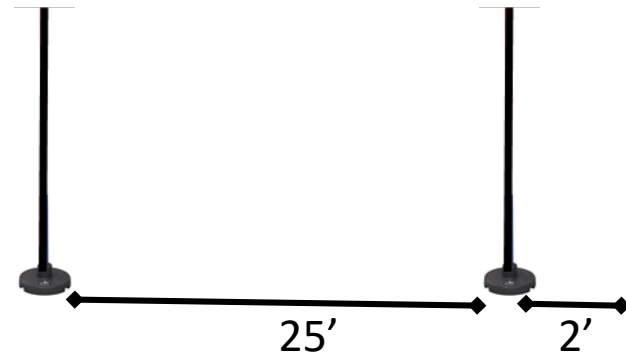
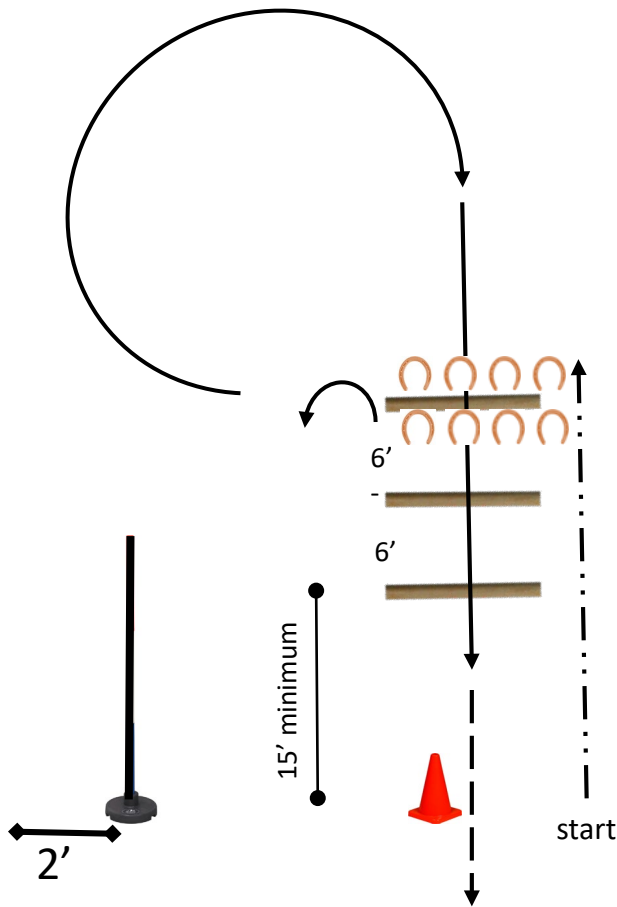

Trail/Rancher #2

1. Cross start line with loop built, carry loop throughout
2. Trot w/energy until horse's body is even with cone, Halt
3. Back 2 lengths or so with energy, then immediately jog forward
4. At or near cone, pick up LEFT lead Lope,
5. Lope partial circle to left, at approximately the half way point, begin your swing, when on the diagonal line, Halt and throw rope
6. **Quickly** re-coil and build loop
7. Then JOG on diagonal line to finish, carrying loop

Equipment Needs

- One, cone, 8-18"

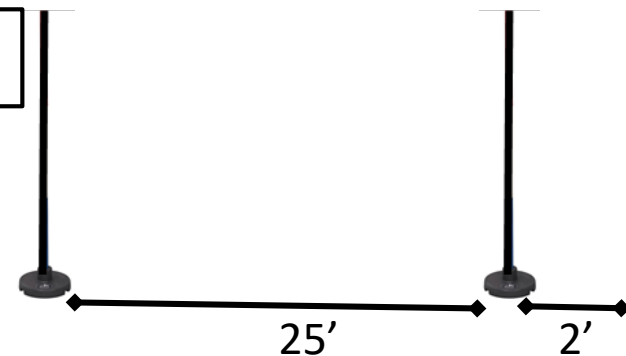
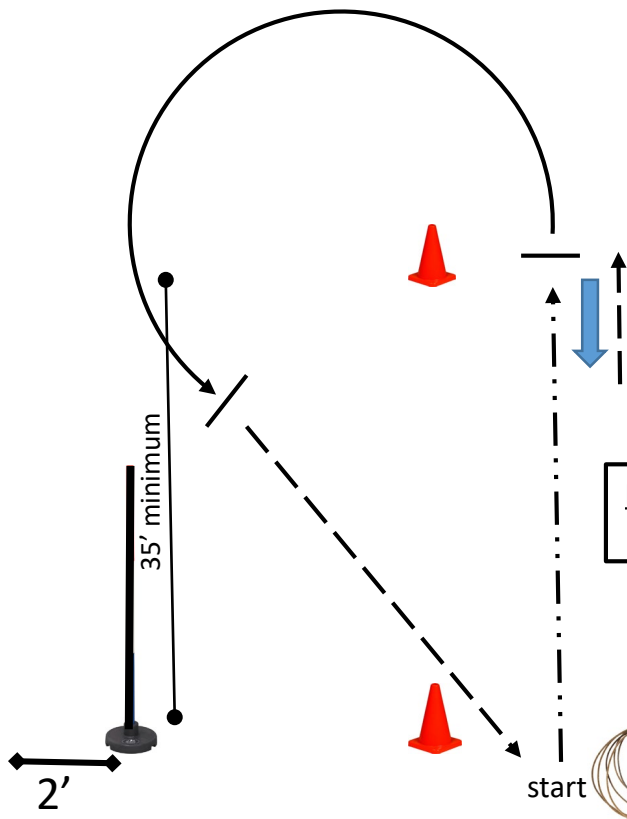

2020-2021

Trail/Rancher #3

1. Lope/Canter RIGHT Lead over ground poles
2. Transition to Jog (English riders, Posting Trot, changing diagonals as appropriate) Serpentine poles as shown
3. After completely clearing the final "gap," HALT
4. Perform a 270° RIGHT Haunch Turn
5. Jog (English Riders, Sitting Trot)
6. Transition to a walk BEFORE crossing start/finish line

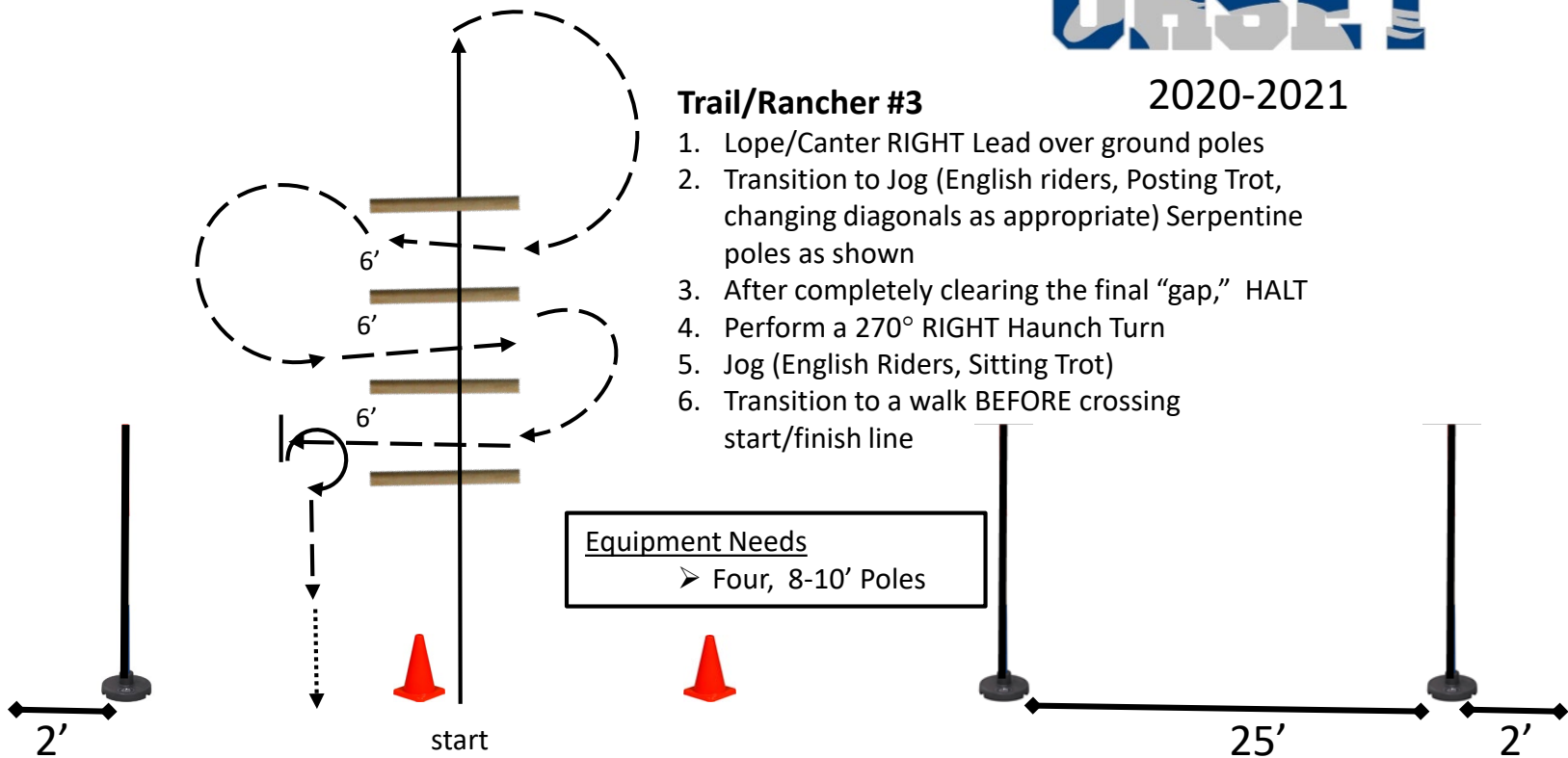

Trail/Rancher #4

1. Jog/Sitting Trot to start, halt when in line with poles, Side Pass RIGHT
2. Pick up LEFT Lead Lope/Canter to other side of poles, when lined up, HALT
3. Side Pass LEFT
4. Then back up 2+ lengths w/energy; settle and balance
5. Perform a 360° LEFT Haunch Turn
6. Immediately pick up the trot (English Riders May Post) and trot through the start/finish line

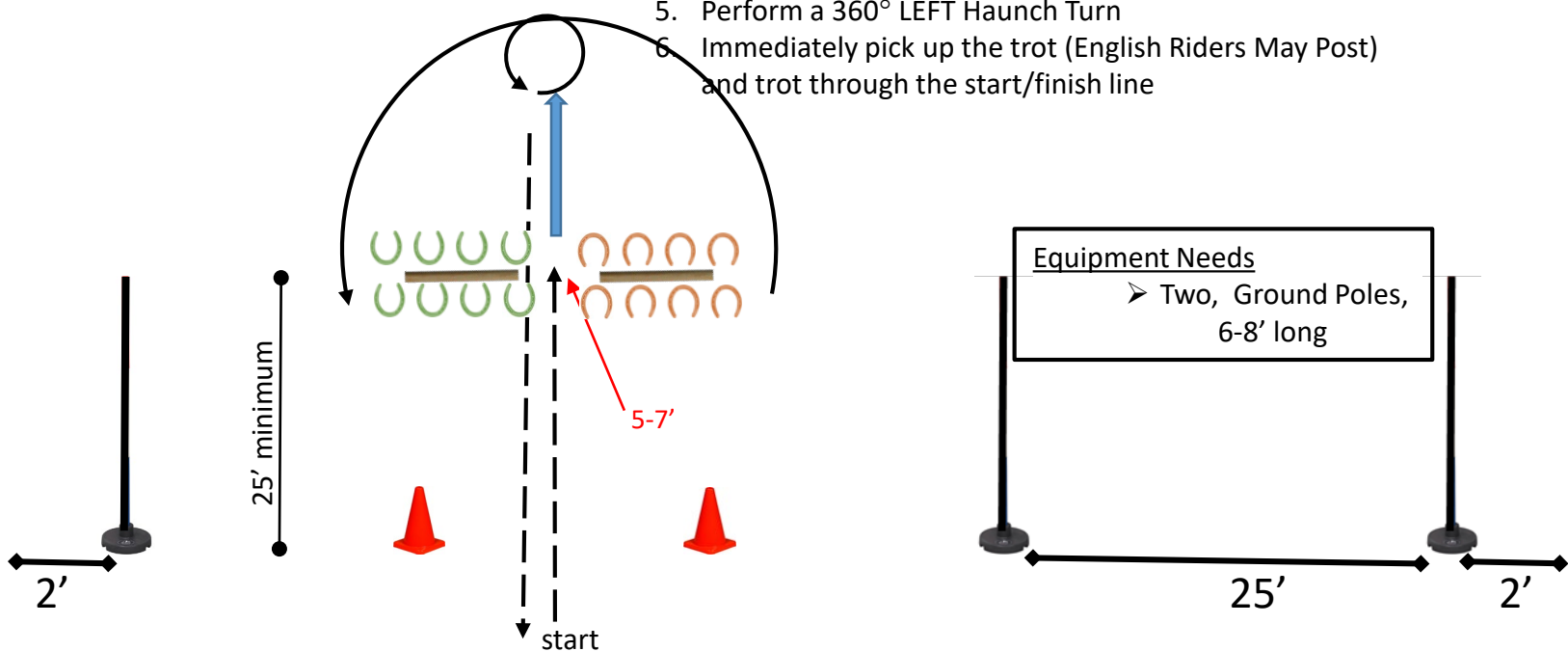

Trail/Rancher #5

1. Lope/Canter LEFT Lead between poles on the right
2. Transition to Jog/Sitting Trot, then pick up RIGHT Lead, continuing straight
3. Begin to circle right and transition to Jog/Trot (English Riders may Post), Over ground pole and proceed to outside of poles
4. When straight again, Extend the Trot over Start/Finish line

Note: 10' space will be larger by the width of the pole.

Equipment Needs
➤ Four, 8' Poles

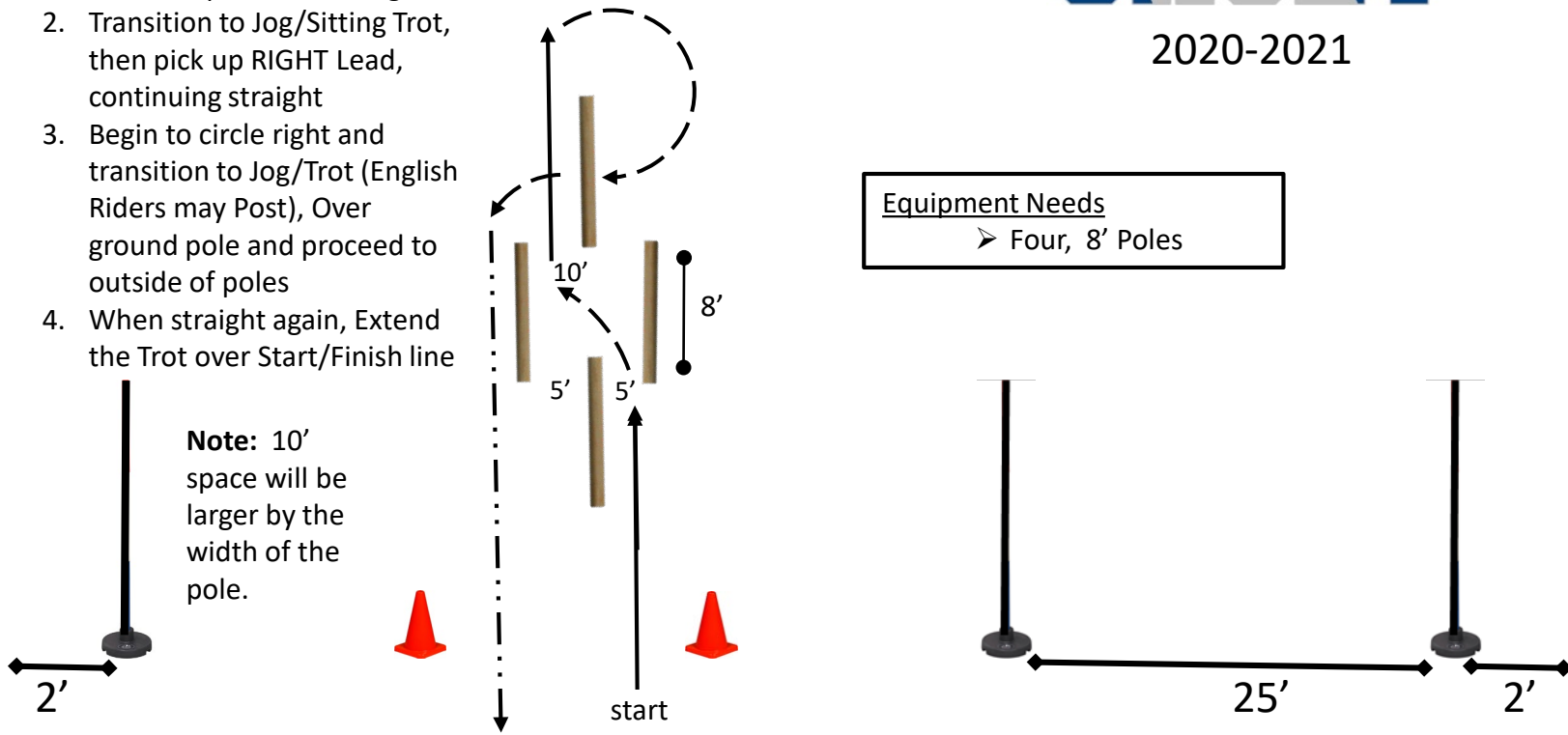

Trail/Rancher #6

1. Lope w/Energy past cone (Lead best for the situation), ROLL BACK left
2. Transition to Extended Trot, ¾ of the way back to line, HALT
3. 180° RIGHT Haunch Turn with energy AND accuracy
4. 180° LEFT Haunch Turn with energy AND accuracy
5. Jog trot back through start/finish line

Equipment Needs
➤ One, Cone 8-18"

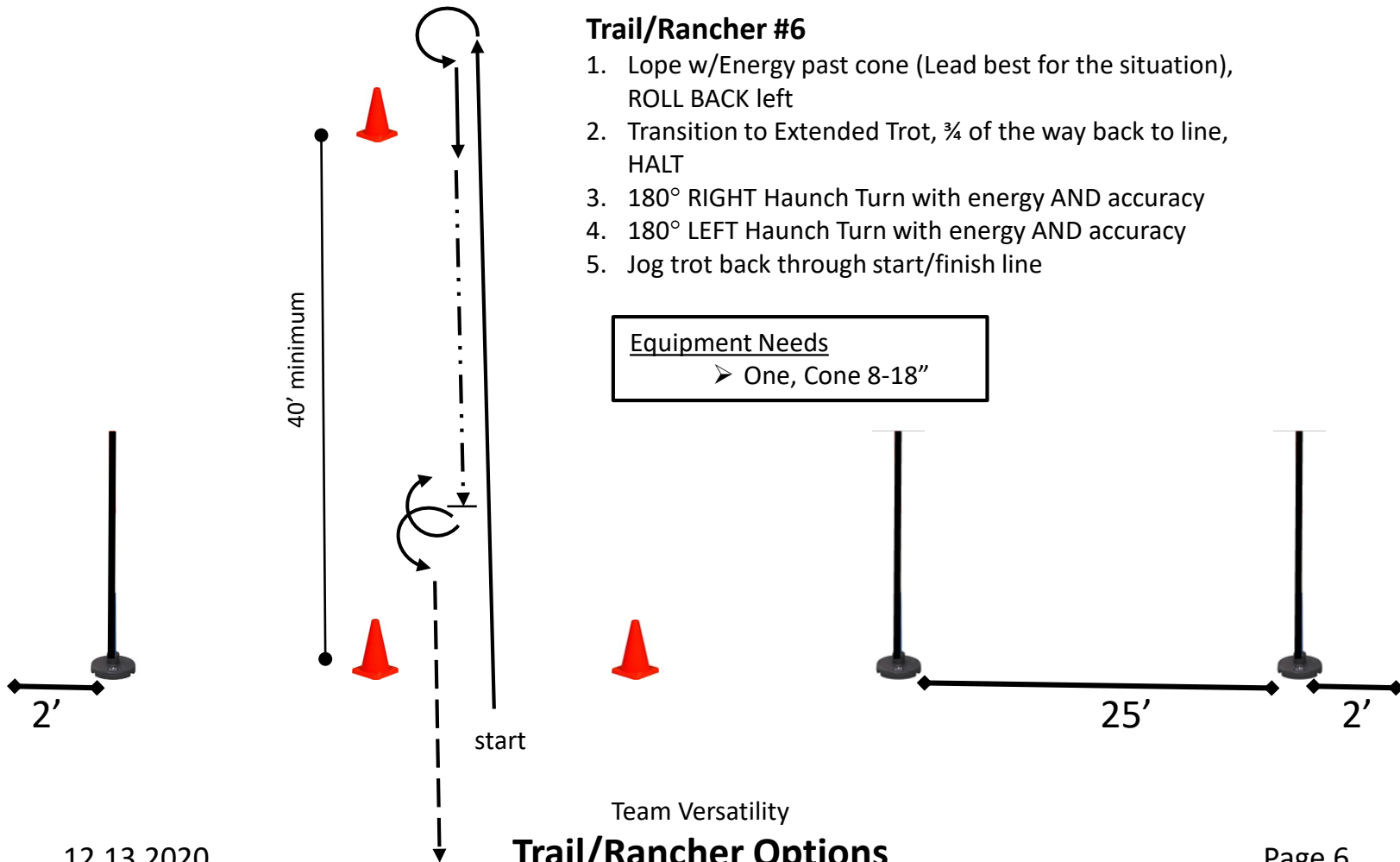

Equitation #1

1. Lope/Canter RIGHT Lead, Circle Right, continue straight up the arena
2. Make your best Lead change, flying preferred.
3. Circle LEFT, begin second circle
4. At midpoint, transition to Jog/Trot (English Riders should Post the Trot) across start/finish line

NOTE: Use your space to benefit your pattern

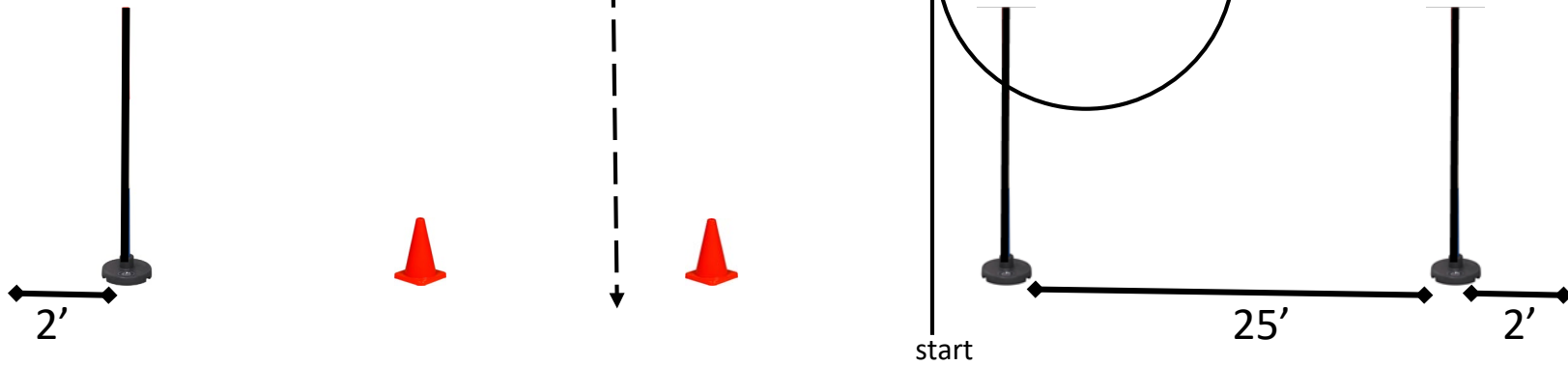

Equitation #2

1. Lope/Canter beginning on the RIGHT Lead demonstrate 2 lead changes.. **Accurate** Flying, Simple or Interrupted will be given equal weight.
2. HALT, 180° Left Forehand Turn
3. Jog/Trot (posting if English) approximately 1/2 back to the start line, HALT
4. Back 6 steps, and immediately job/sitting trot out of the back, across start/finish line

NOTE: Use your space to benefit your pattern

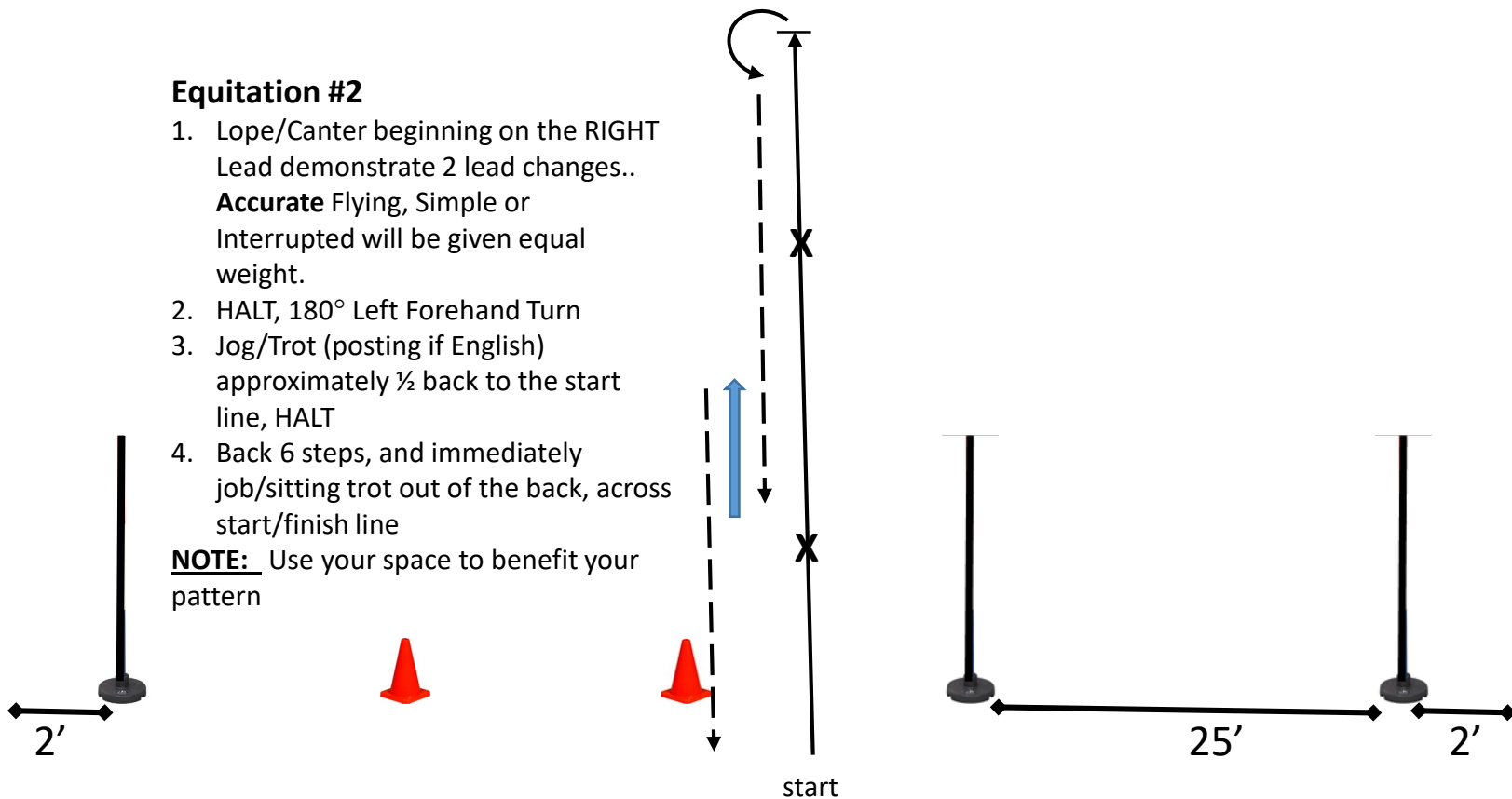

Equitation #3

1. Jog/Sitting trot straight ahead
2. Lope/Canter LEFT lead and Circle
3. Make your BEST Lead Change and Circle RIGHT completing the figure 8
4. Continue on the RIGHT lead and begin to turn LEFT, then transition to Jog/Posting Trot
5. Extend the trot and continue until crossing start/finish line

NOTE: Use your space to benefit your pattern

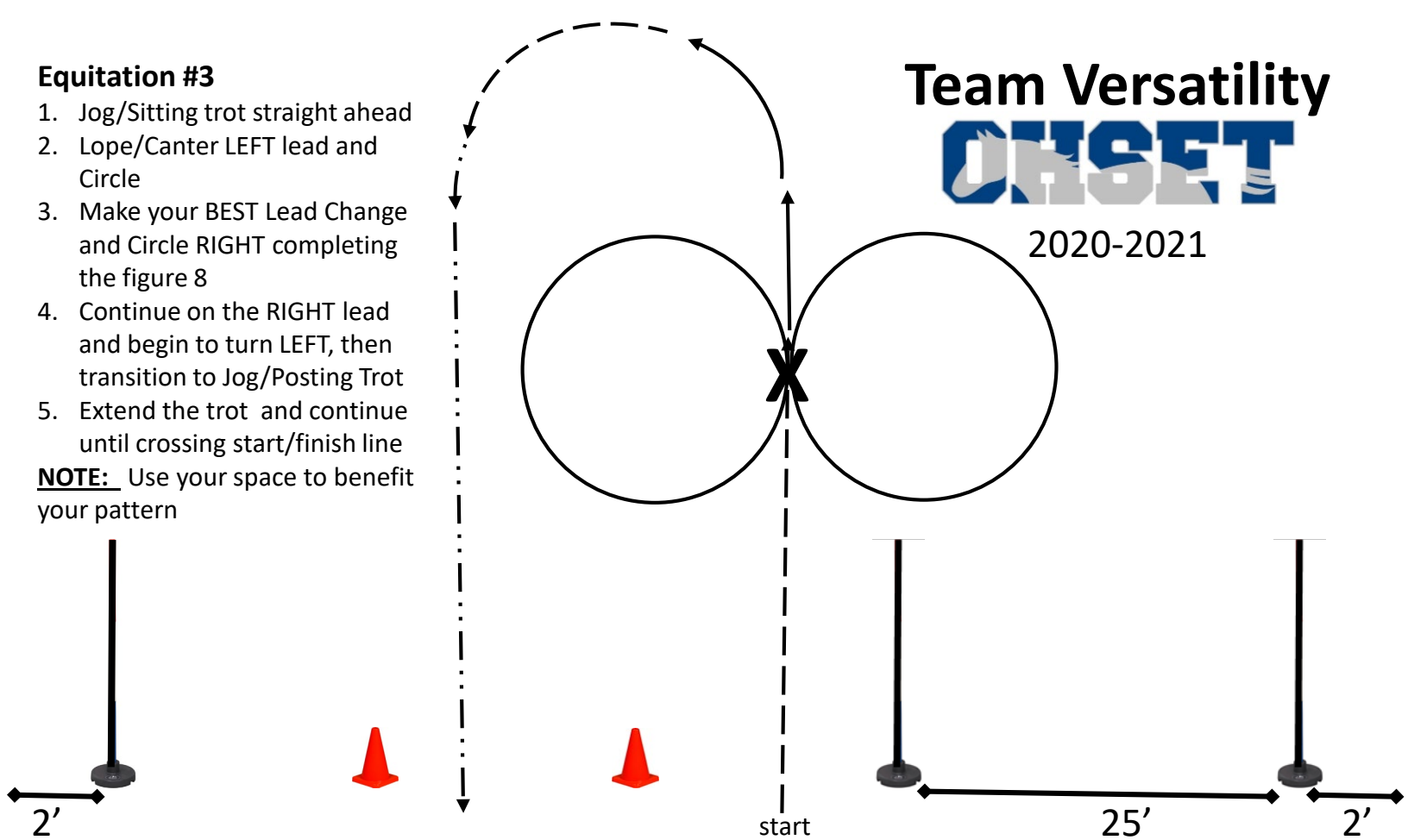

Equitation #4

1. Lope/Canter beginning on the RIGHT Lead demonstrate an INTERRUPTED lead change and circle LEFT
2. Just before completing your circle, HALT, and do a 180° LEFT Haunch Turn
3. Pick Up the RIGHT Lead Lope/Canter circle RIGHT along a similar track as previous circle
4. When you are facing the start/finish line, transition to the Jog/Sitting Trot
5. Approximately $\frac{3}{4}$ down the straight away, HALT
6. Back 6-8 Steps and immediately Jog/Sitting Trot out across start/finish line

NOTE: Use your space to benefit your pattern

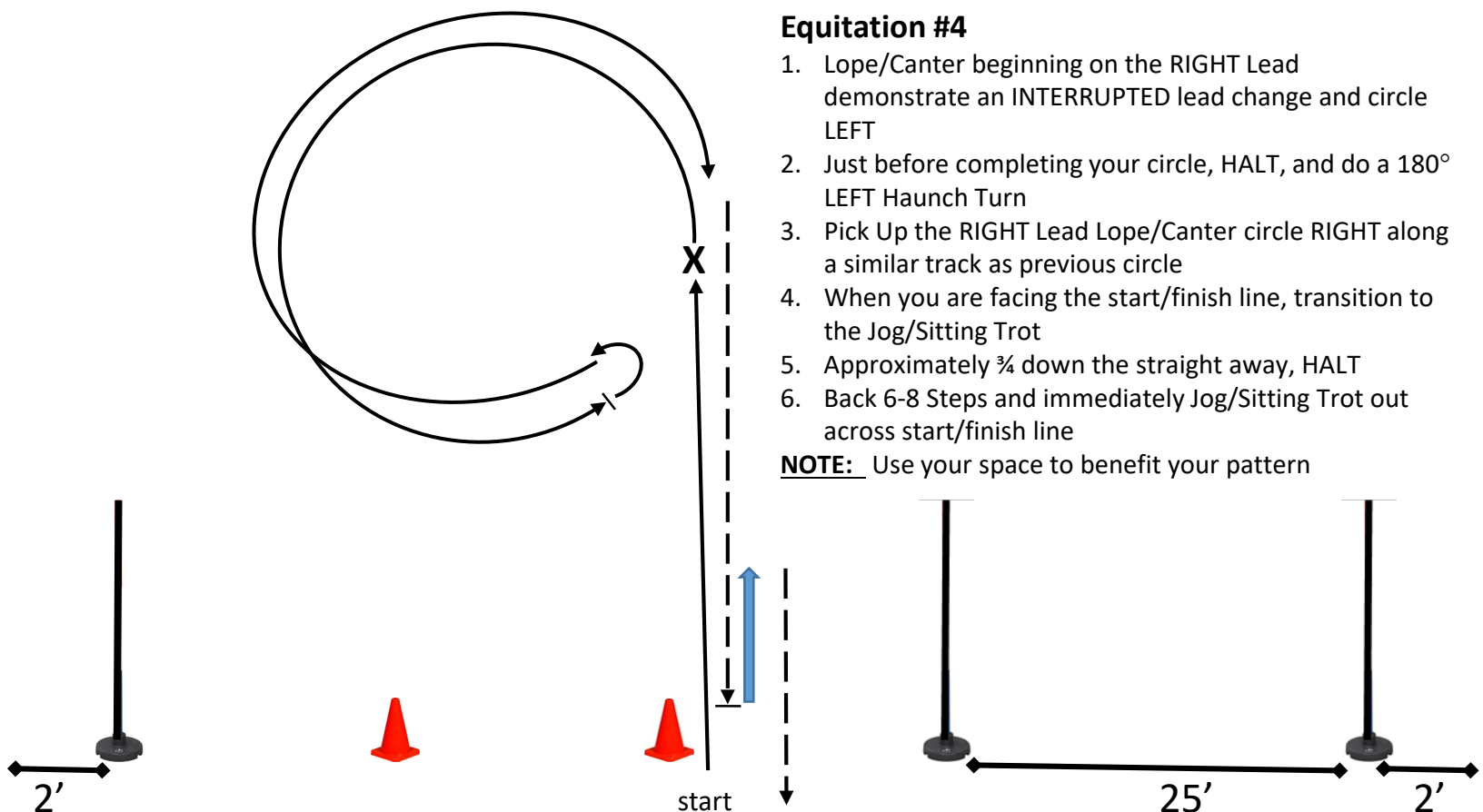

Team Versatility

OHSET

2020-2021

Equitation #5

1. Lope/Canter LEFT lead
2. SIMPLE lead change to RIGHT lead (counter canter)
3. Once on straight away, Jog/Posting Trot
4. Turn the corner down the diagonal line and EXTEND the trot across Start/Finish Line

NOTE: Use your space to benefit your pattern

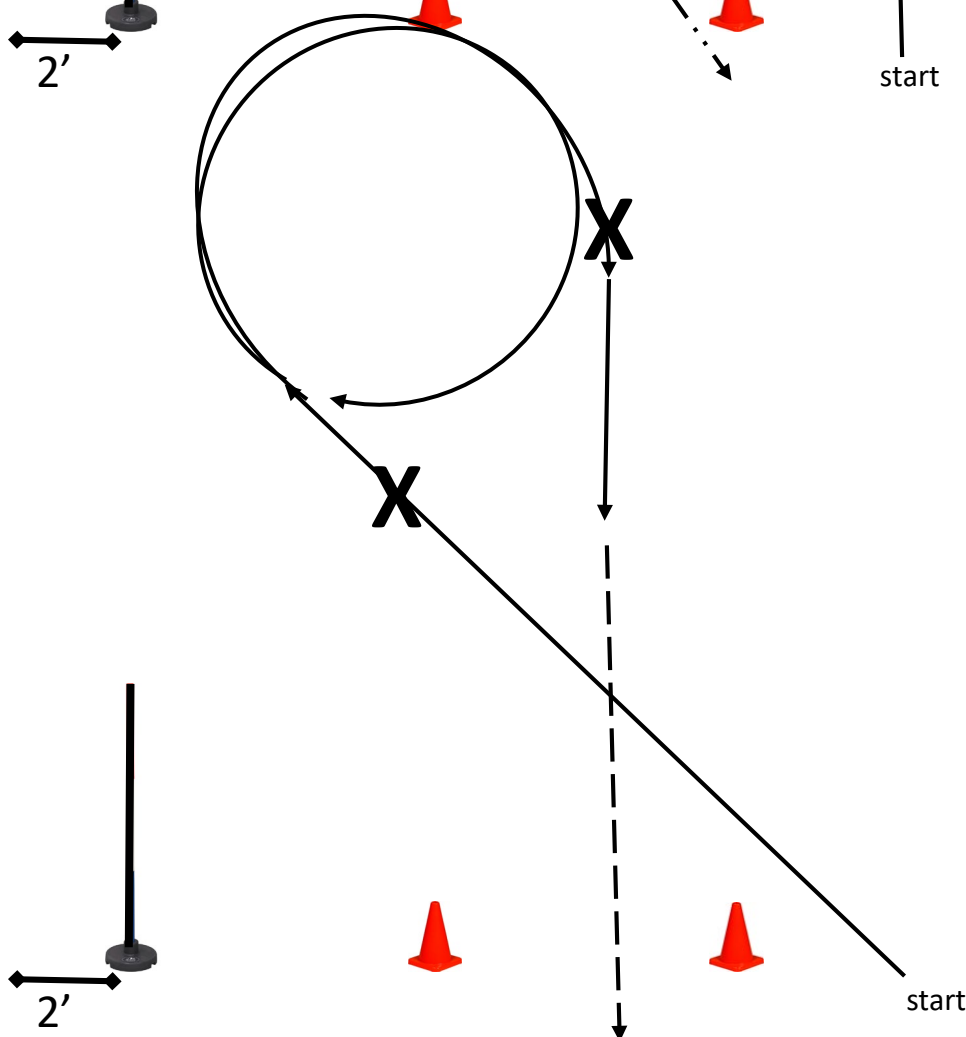
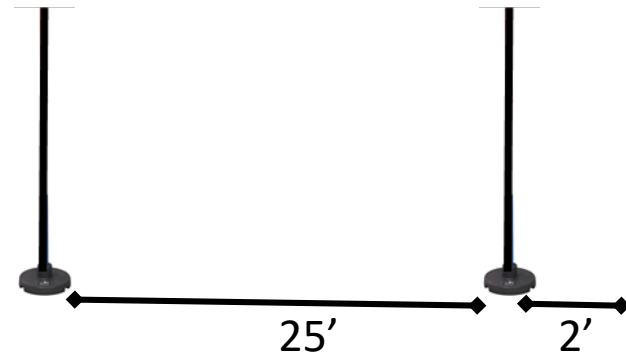
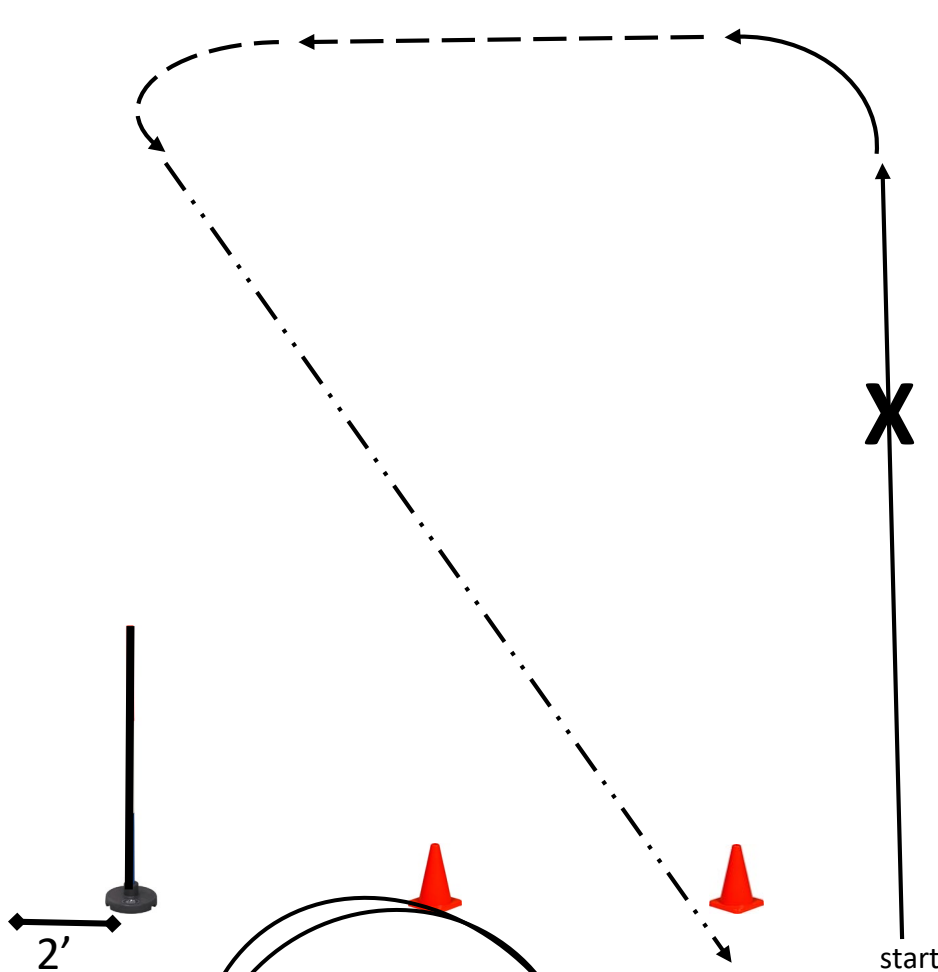

Equitation #6

1. Lope/Canter across the diagonal line beginning on the LEFT lead,
2. Perform a flying or simple lead change (flying preferred) to the RIGHT lead and circle RIGHT
3. Begin a second circle on the same track as the first and then head straight to the start/finish line
4. Once you are straight, perform an Interrupted lead change to the LEFT lead
5. About 1/2 way down, transition to a Jog or Sitting Trot and continue across the start/finish line

NOTE: Use your space to benefit your pattern

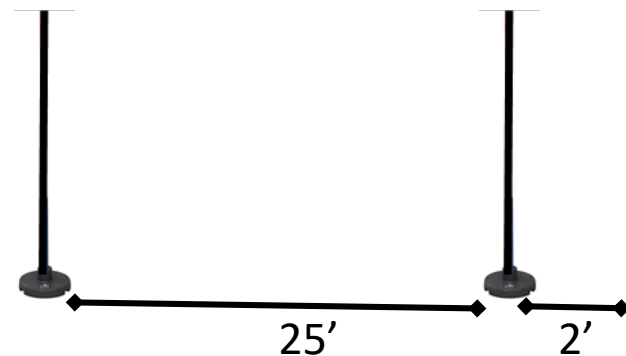

Team Versatility



2020-2021

Timed Event #1

1. Run down RIGHT side of barrel, turn LEFT,
2. Circle the barrel 1 ½ times and return to finish line

Equipment Needs

- One, 55 gal Barrel



Timed Event #2

1. Run down LEFT side of poles, turn RIGHT
2. Circle BOTH end poles and begin 2nd circle, turning a tighter RIGHT and come back toward the finish line through the middle of the end poles
3. Circle the middle pole LEFT and after completing the circle
4. Go straight across the finish line

Equipment Needs

- Three Poles

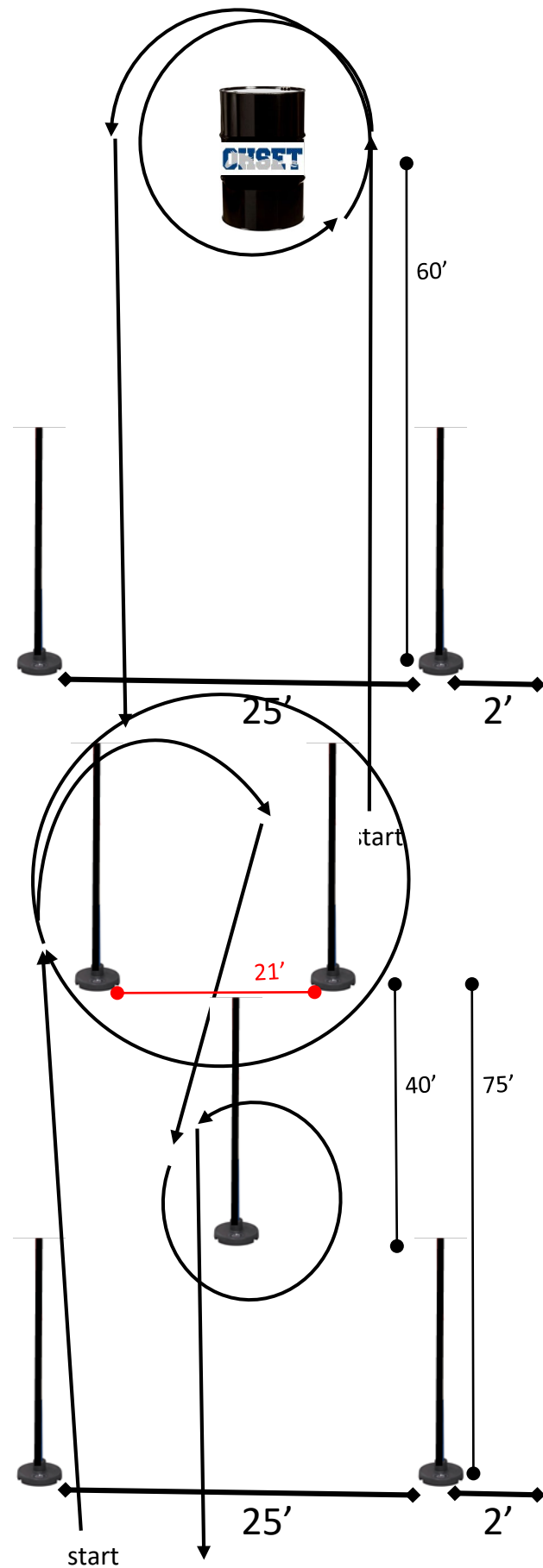
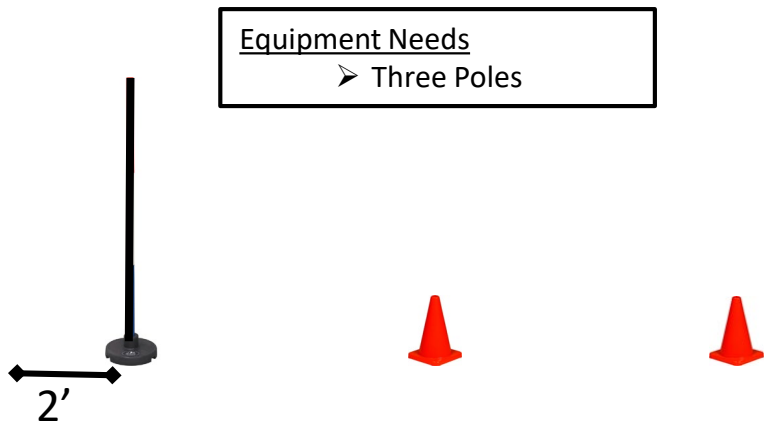

2020-2021

Timed Event #3

1. Run down RIGHT side of barrels, begin to circle end barrel then cross and "figure 8" barrels (First turn to the LEFT, Second turn to the RIGHT, then LEFT turn again)
2. Proceed straight to Finish

Equipment Needs

- Two, 55 gal Barrel

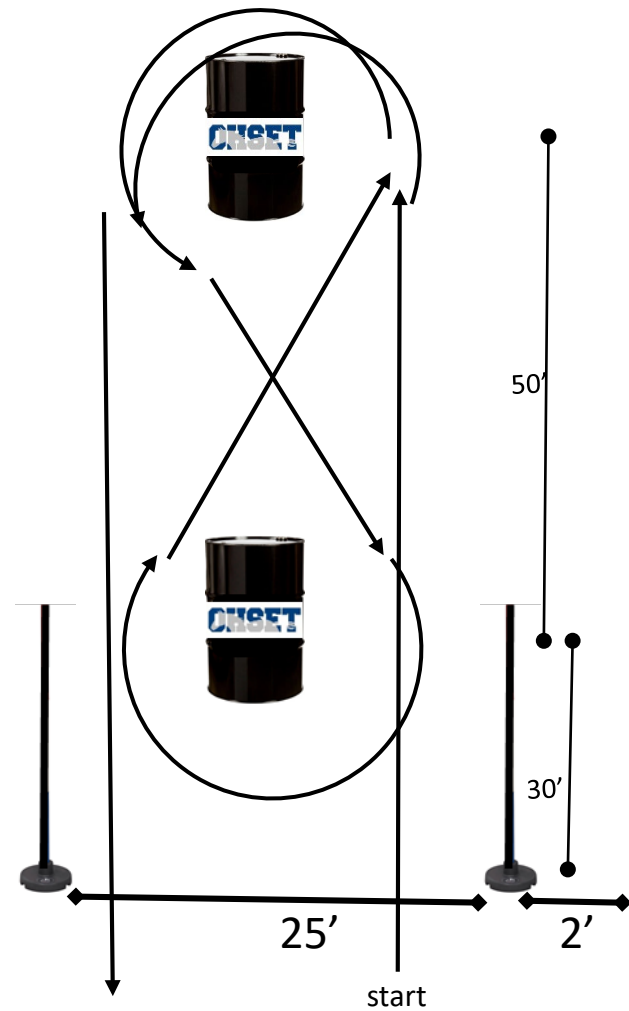
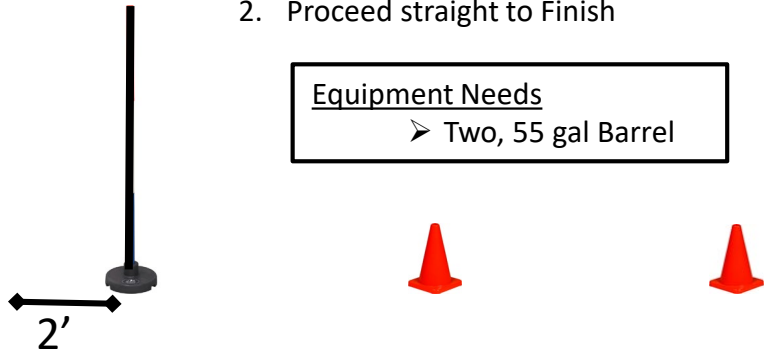

Timed Event #4

1. Poles with only 3 poles
2. Run down either side
3. Turn and weave poles, turning last pole and weaving all three poles back,
4. Turn final end pole and head straight for finish
5. This pattern can be run from either side

Equipment Needs

- Three Poles

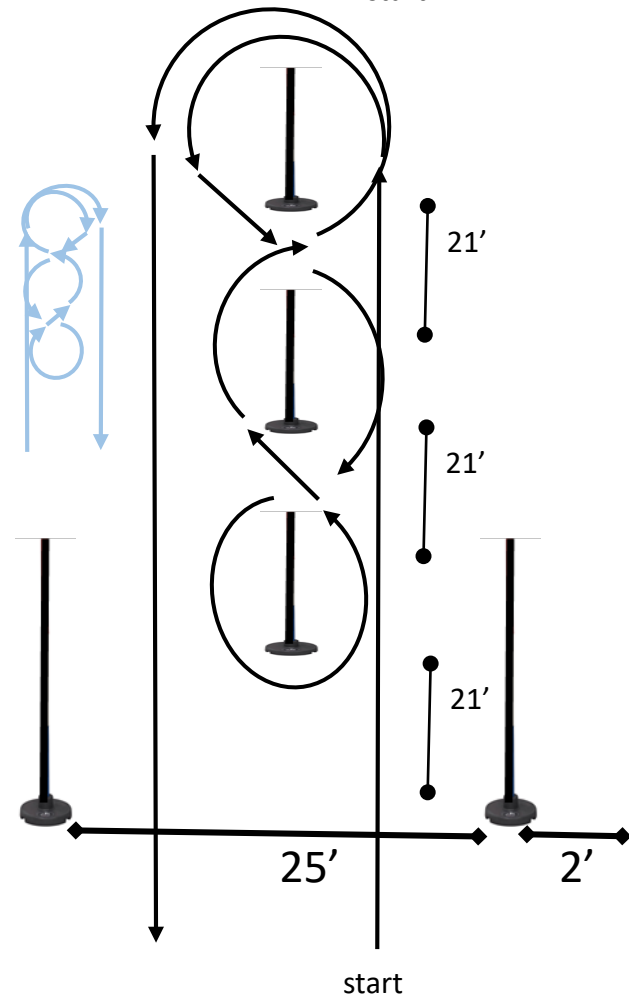
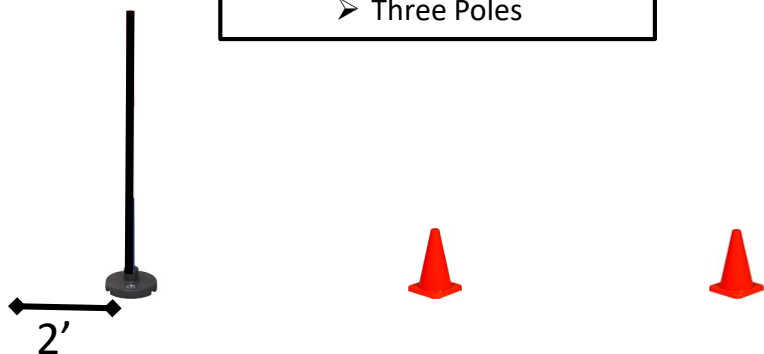

Team Versatility

ONSET

2020-2021

Timed Event #5

1. Run Inside of barrels
2. Turn EITHER direction, circle the barrel, then make the opposite turn on the other barrel
3. Without completely circling the barrel, proceed straight to Finish
4. Proceed straight to Finish

Equipment Needs

- Two, 55 gal Barrel

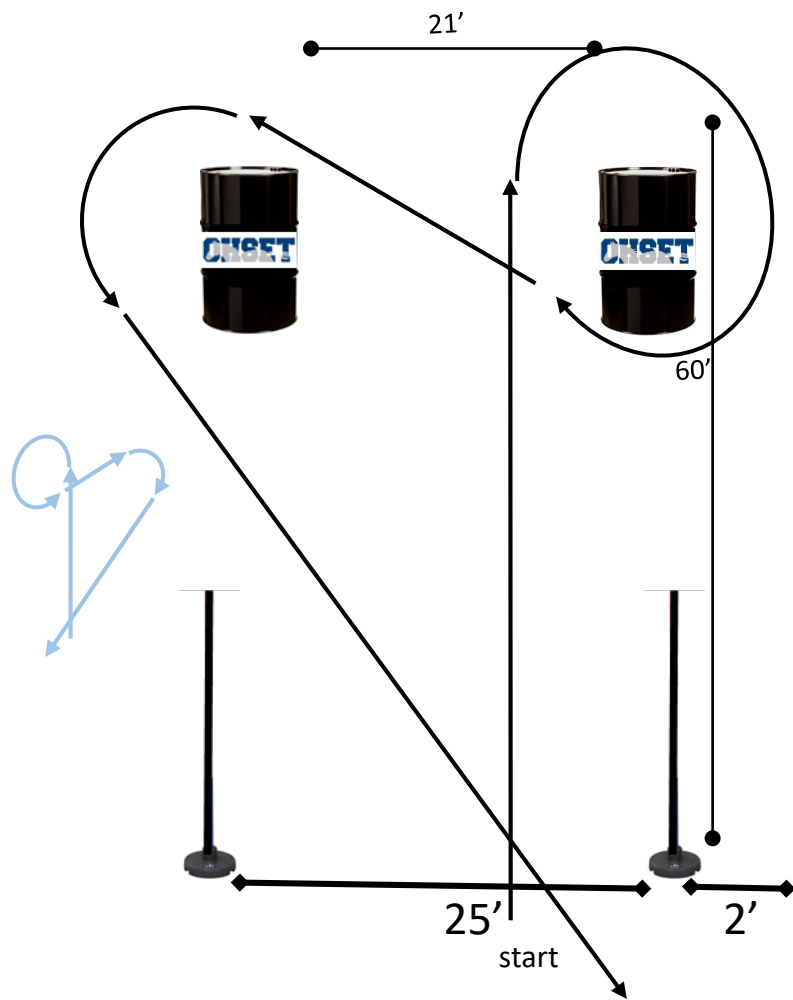
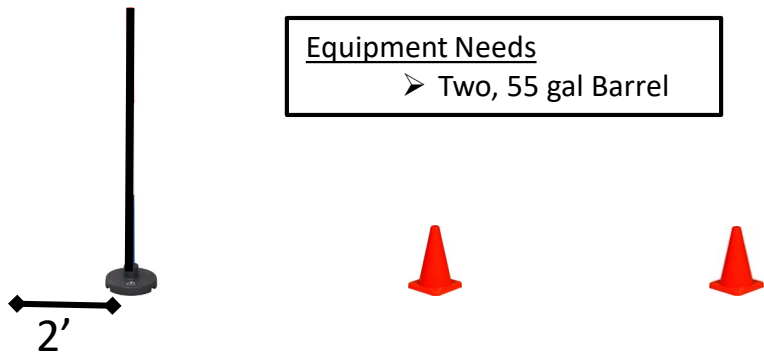

Timed Event #6

1. Run down one side of barrel, pick up flag
2. Turn down other side and head for finish
3. Container can be circled to pick up flag – container event rules/deductions apply
4. This pattern can be run from either side

Equipment Needs

- Small Barrel (Ind Flag size)
- One Flag

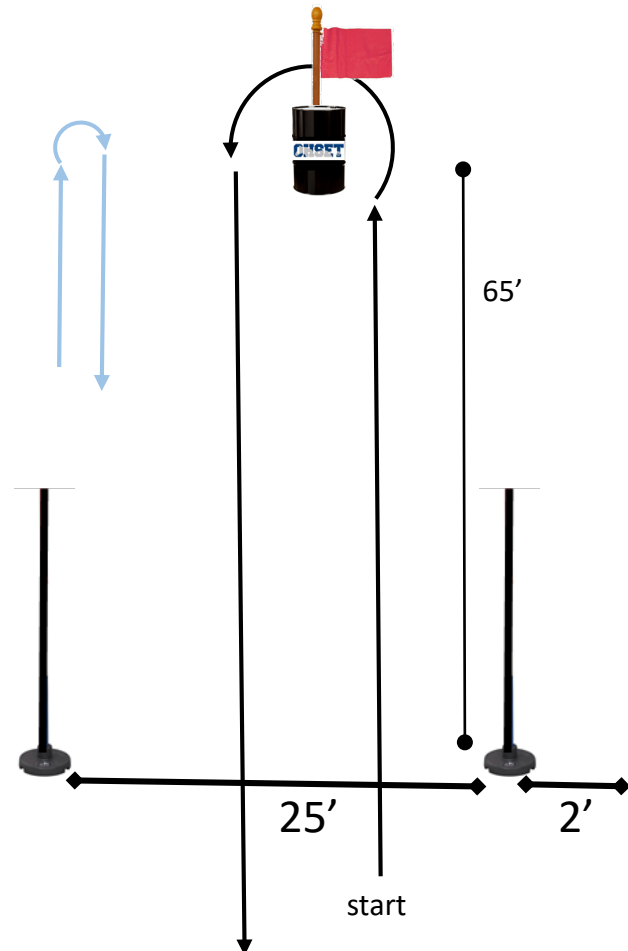
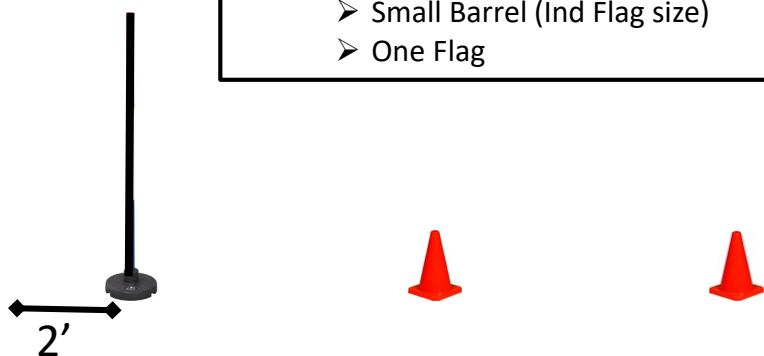

Team Versatility

Timed Event Options